



MAIN TOOL & MANUFACTURING Co., INC.

7850 BEECH STREET NE • FRIDLEY, MN 55432
763-571-1772 • FAX 763-571-3738
WWW.MAINTOOL.COM

CNC LATHES

1 BULLARD - VTL

71" swing, 35" height/length

2 MONARCH ULTRA CENTER

Twin spindle (15" main, 13" sub), 6 axis with Live Tooling, 24" max swing.

1 DAEWOO PUMA 400

28" swing, 41" between centers, 4 5/8" hole thru spindle

1 OKUMA LH-40-N

30" swing, 118" between centers, 7" over the slide

1 DAEWOO PUMA 10HC

19 1/2" swing, 14" between centers

1 TAKISAWA TS-10

3 axis mill turn, barfeed capabilities up to 1 5/8", add'l chuck up to 6" dia.

CNC MILLS

Vertical

OKK VERTICAL MACHINING CENTER MODEL 820

20 HP, 3,000 RPM, max. Load on table 4,400 lbs., X 62.9" Y 32.2" Z 28.3"

OKK VERTICAL MACHINING CENTER MODEL 800

20 HP, 3,000 RPM, max. Load on table 4,400 lbs., X - 63 1/2" Y - 31 1/2" Z - 29"

OKUMA-HOWA NO. 5 VERTICAL MACHINING CENTER

10 HP, 3650 RPM, max. Load on table 2,200 lbs., X - 39" Y - 23" Z - 21", w/ SMW rotary table-model RT 315 -w/ indexing to .001 of a degree

MAZAK VTC 41

7 HP, 7,000 RPM, max. Load on table 300 lbs., X - 22" Y - 16" Z - 20"

Horizontal

2 OKK MACHINING CENTER MODEL 700

20 HP, 3,000 RPM, X - 59" Y - 31 1/2" Z - 31 1/2", 5th axis table

1 OKK MACHINING CENTER MODEL 560

15 HP, 4,000 RPM, X - 28" Y - 22" Z - 22", w/ pallet changer

2 MITSUBISHI MACHINING CENTER MODEL MPA H50A

15 HP, 6,000 RPM, X 24.8" Y 24.8" Z 19.7", pallet changer, 5th axis table

1 OKK MACHINING CENTER MODEL 400

15 HP, 3,000 RPM, X - 24" Y - 18" Z - 17", indexing table

MANUAL LATHES

- STANDARD MODERN ENGINE LATHE
17" swing, 48" between centers, 3 1/4" hole thru spindle
- STANDARD MODERN ENGINE LATHE
20" swing, 60" between centers, 3 1/4" hole thru spindle
- WAFUM ENGINE LATHE
24" swing, 10 ft. between centers, 5 5/8" hole thru spindle
- KING VERTICAL TURRET LATHE
40" swing, 30" height, 40 HP, w/ digital readout to .0001

MANUAL MILLS

- 3 BRIDGEPORT # 1 - 1-1 1/2 HP, w/ digital readouts to .0001 and power feeds

BROACH

- 1 RED RING HDE-5-60 - 5 ton horizontal broach, w/ 60" stroke

GEAR SHAPER

- 1 FELLOWS with 19" riser.

INSPECTION EQUIPMENT

- | | |
|------------------------------|-------------------------------------|
| ZEISS/Numerex CMM | Granite inspection surface plates |
| H - 18" D - 28" L - 28" | Optical Comparator .0001 resolution |
| Profilometers | Hardness tester |
| ID and OD micrometers to 24" | Depth micrometers to 12" |
| ID and OD verniers to 60" | Dial bore gages to 24" |
| Gage block sets | |
| Groove micrometers to 8" | |

All inspection equipment is calibrated and certified traceable to the NIST.

MATERIAL HANDLING

- | | |
|---------------------------------|----------------------------------|
| 1 NISSAN Forklift - 5,000 lbs. | 2 1 - Ton electric boom hoists |
| 1 WHITE forklift 5,000 lbs. | 3 1/2 - Ton electric boom hoists |
| 1 TOYOTA Forklift - 5,000 lbs. | 4 300# - Production hoists |
| 4 Pallet jacks up to 2,000 lbs. | 1 Weight scale up to 3,000 lbs |
- Misc. chains, nylon straps, magnetic lifting plates, lifting clamps, and dollies

SAWS

- | | |
|--------------------------------------|--------------------------------|
| 1 DOALL - 12" x 16" automatic saw | 1 GROB - 24" vertical band saw |
| 1 SUPER BROWN - cold saw w/ air vise | 1 ABRASIVE - cut off |
| 1 KALAMAZOO - 6" x 10" cut off | |

GRINDERS

- | | |
|------------------------------------|-----------------------------|
| 1 DOALL - 6" x 18" surface grinder | 1 DELTA TOOLMAKER - grinder |
| 1 STERLING - drill grinder | 6 Grinders |

DRILLS

- 1 RADIAL ARM DRILL - 4 ft., 10 HP
- 2 5 Station drill presses
- 3 20 floor models

WELDERS

- 1 PANASONIC ROBOTIC WELDER
- 1 MILLER - Wire feed welder
- 2 Gas Welders
- 1 Arc Welder

MISCELLANEOUS

- | | |
|--------------------------------|--------------------------|
| 1 50 TON HYDRAULIC PRESS | 1 TAP BURNER |
| 4 BELT SANDERS - 1" - 6" width | 2 AIR FEED TAPPING TABLE |
| 3 SUNNEN HONES | |



MAIN TOOL & MANUFACTURING Co., INC.

7850 BEECH STREET NE • FRIDLEY, MN 55432
763-571-1772 • FAX 763-571-3738
WWW.MAINTOOL.COM

OUR GOAL IS TO EXCEED YOUR EXPECTATIONS

*We will work side by side with you to solve your problems,
and meet your customers needs*

*We bring over fifty years of experience to the table...
...and we will perform to the highest standard in all areas:*

- Quality
- Workmanship
- Service
- Price
- Delivery
- Got Kan Ban? Bring it on.

What we can do for you:

- Machining of small to large parts including weldments.
- Precision CNC milling and turning.
- Cell operations
- Prototypes and quantities from one to ten thousand and more...
- Milling & turning of all materials.
- Complete assemblies.



MAIN TOOL & MANUFACTURING Co., INC.

7850 BEECH STREET NE • FRIDLEY, MN 55432
763-571-1772 • FAX 763-571-3738
WWW.MAINTOOL.COM

COMPANY PROFILE

- ESTABLISHED IN 1955
- 22,000 SQ. FOOT, AIR CONDITIONED BUILDING
- QUALITY MANAGEMENT SYSTEM COMPLIANT TO MIL-I-45208A
AND ISO 9001:2001
- PRESIDENT: LEONARD LINDELOF
- SALES MANAGER: DUANE SPANIER
- OFFICE MANAGER: JAN HANSON
- SALES/ESTIMATOR: DAN CARTER
- QUALITY MANAGER: TIM WILLIAMS
- SHOP SUPERVISOR: DEAN LAGE
- TURNING SUPERVISOR: JOHN PELZEL

GOT BIG?

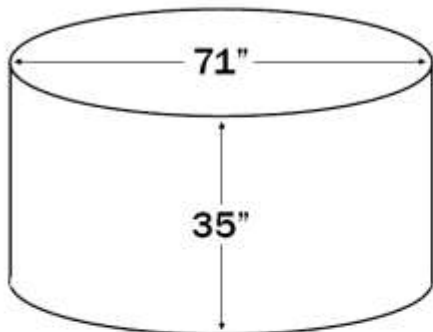

CNC VTL

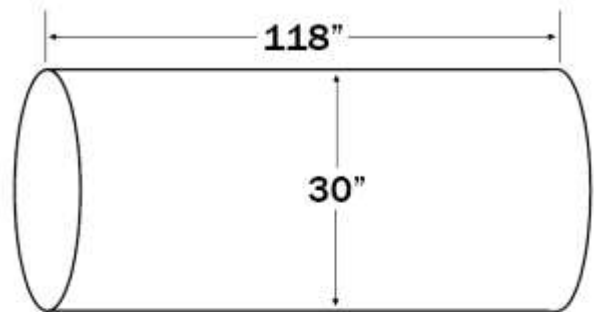

CNC LATHE

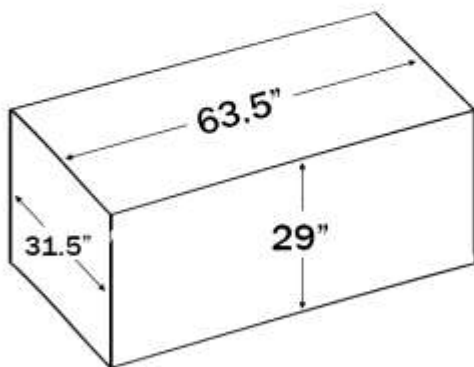

CNC VERTICAL MILL

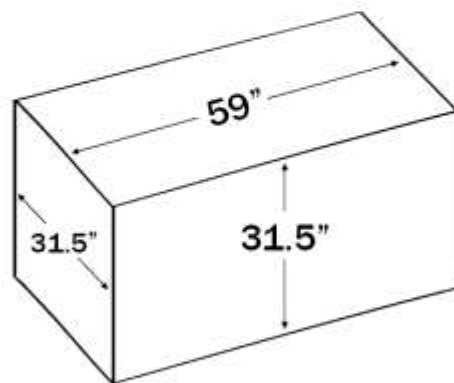

CNC HORIZONTAL MILL

Small to large, one to ten thousand...or more. We can solve your problems and meet your delivery needs. Kan Ban? Bring it on.

We can do small, but at Main Tool...

WE LIKE IT BIG!



MAIN TOOL
& MANUFACTURING Co., INC.

7850 BEECH STREET NE • FRIDLEY, MN 55432
763-571-1772 • FAX 763-571-3738
WWW.MAINTOOL.COM